

Mercury HB

Series

*Explosion
Proof*

Industrial highbay LED fixture for potentially explosive atmospheres. Zone I and II hazardous areas, zone 20, zone 21, zone 22 and IIA, IIB, IIC explosive gas atmosphere. It is one of the highest quality fixtures in its price range.



IECEX



RoHS
compliant

CB

> Mercury HB <

Light Efficiency

180 LM/W

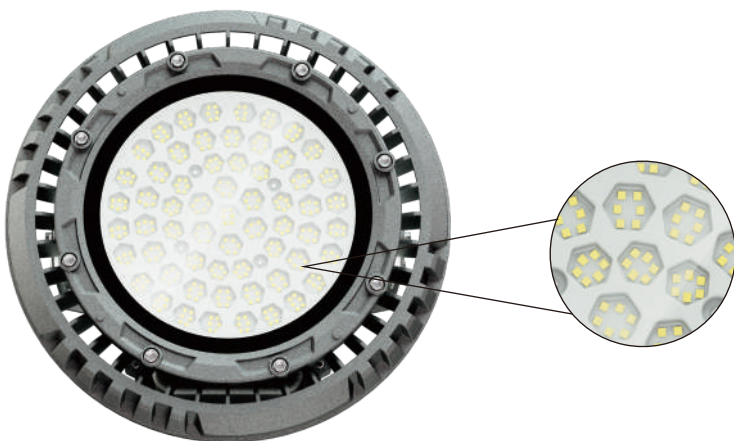

Stable luminous
High-quality led chip



II 2G Ex db mb IIB T4 Gb
II 2D Ex tb IIIC T(95°C) Db





IP66 Waterproof
6KV/10KV Surge Protection
AkzoNobel Coating
Best Corrosion Proof



Precise Angle Rotation
Free Rotation 180 Degrees



Application

Zone 1 Zone 2
Zone 21 Zone 22

Applied to oil fields, oil refineries, offshore oil platform, power plants, gas stations, oil tanks, wharf, tunnel, pumping station, substation, the military base, etc. Zone I and Zone II Hazardous Locations, Zone 20, Zone 21, Zone 22 and II A, IIB, IIC explosive gas atmosphere.



Chemical industry
Oil and natural gas extraction
Petrol station
Offshore
Marine sector



Tank vehicle
Shipyards
Power plant
Refinery
Rescue service
Aviation



Sugar refinery
Grain and feed industry
Fertiliser industry
Flour milling
Pharmaceutical industry
Waste treatment plant
Timber industry





Features

- Housing: Pure Aluminum
- Thermal Conductivity: 226 W/m·K
- Led: Cree 3030
- CRI: Ra>80
- SDCM: <6
- Power Factor: >0.95
- THD: <15
- Driver: Meanwell
- Driver Efficiency: >93%
- Protection: OTP, OCP, OVP, SCP
- Surge Protection: 6KV
- Waterproof: IP66
- Impact Test: IK08
- Electrical: 85-305V, 50/60Hz
- Operating Temperature: -40~60°C
- TM21: L90B10>50,000H
- Lifetime: 50,000H

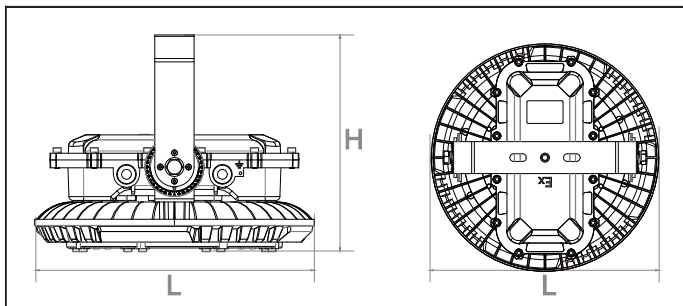

Optional functions:

ZigBee ·DMX ·DALI 0/1~10V

Optical options:

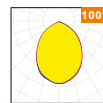

160~180 lm/w

5 YEARS WARRANTY

Meanwell Driver

Cree LED

Model	Watt	Voltage	Lumen	CRI	IP	Dimension
U-EX60-M-HB-60-5	60W	85~305V	10800LM	>80	IP66	φ 356*H275mm
U-EX80-M-HB-80-5	80W	85~305V	14400LM	>80	IP66	φ 356*H275mm
U-EX100-M-HB-100-5	100W	85~305V	17000LM	>80	IP66	φ 356*H275mm
U-EX120-M-HB-120-5	120W	85~305V	20400LM	>80	IP66	φ 356*H275mm
U-EX150-M-HB-150-5	150W	85~305V	24000LM	>80	IP66	φ 356*H275mm
U-EX200-M-HB-200-5	200W	85~305V	32000LM	>80	IP66	φ 356*H275mm

Packing

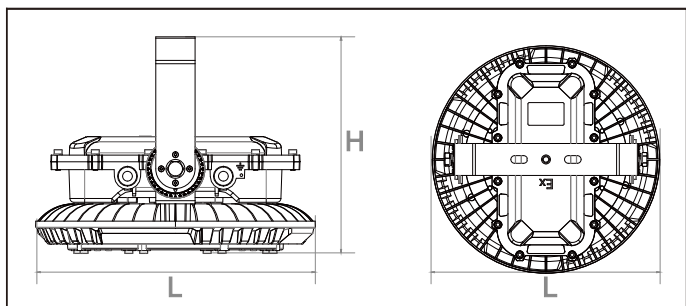

Fixture

Model	Dimension (mm)	Outer Carton(mm)			QTY / Outer CTN	Luminaire	
		L	W	H		NW(kg)	GW(kg)
U-EX60-M-HB-60-5	356*275	435	415	270	1	8.50	9.30
U-EX80-M-HB-80-5	356*275	435	415	270	1	8.50	9.30
U-EX100-M-HB-100-5	356*275	435	415	270	1	8.50	9.30
U-EX120-M-HB-120-5	356*275	435	415	270	1	8.50	9.30
U-EX150-M-HB-150-5	356*275	435	415	270	1	8.50	9.30
U-EX200-M-HB-200-5	356*275	435	415	270	1	8.50	9.30